



*General Information*

# KilltheSpill

## Company Information

**Mann Teknik AB is the manufacturer of the DDCouplings®, a full range of Dry Disconnect Couplings for clean, safe and spill free handling of fluids, gases and bulk powders.**

Our years of experience in these diverse fields have given us the opportunity to accumulate extensive knowledge about applications in the many types of industries in which our couplings have been and can be used.

We are continuously striving to develop and upgrade the design and performance of our products; so that we are always in a position to meet the constant changes in the environments our products

can be used in. They are in use in installations all over the world, especially where certification is a prerequisite and are certified by TÜV, Apragaz, Veritas, TDT, plus regionally required approvals.

Mann Teknik AB are certified to ISO9001:2008. The products are CE-labeled. The main products are certified to PED, the European Pressure Equipment Directive and ATEX, the European directive for Equipment intended for use in

Potentially Explosive Atmospheres. The products are produced in accordance with several important standards, e.g. the NATO STANAG 3756.

**ATEX approved**



### Contact Mann Tek

Phone: +46 501 39 32 00  
Email: sales@mann-tek.com

[www.mann-tek.com](http://www.mann-tek.com)

SMILE-PLUSS SIA Technical centr DANTEC Phone: +371 67352561, +371 29214098 Fax: +371 67352386

Email: office@sptech.lv, info@dantec.lv Web site: www.smaile-pluss.lv Address: Tvaika 52, Riga, LV1005, Latvia



# DDCouplings - The main product

Mann Tek has knowledge from design, production and marketing of DDCouplings® since 1977.

The main product is the DDCouplings® for spill free liquid handling. The products are marketed through independent representatives in more than 30 countries.



According to NATO STANAG 3756

## Advantages

- **Easy to handle**  
Push and turn - free flow.  
Turn and pull - closed.
- **Time saving**  
No need to drain hoses or pipe systems.
- **Economical**  
No loss or spillage of liquids at connection or disconnection.
- **Safe**  
The valve cannot be opened until the unit is coupled.
- **Environmentally friendly**  
Accidental spillage eliminated.
- **Reliability**  
No loss or spillage of liquids at connection or disconnection.

## How it works - The coupling function

The principle of operation is similar for all types of Mann Tek Couplings

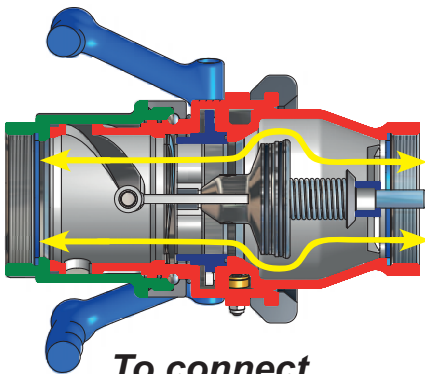

**To connect**  
Push and turn - it's coupled  
- full flow

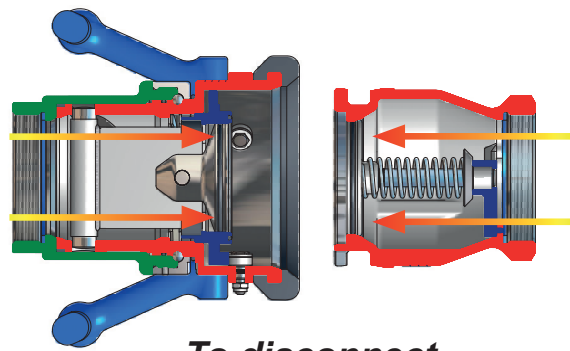

**To disconnect**  
Turn and pull - it's released  
- no spillage

## Mann Tek products

Mann Tek products are used for safe and environmentally friendly handling of liquids, chemicals, petroleum and gases. Within the Mann Tek product range you will have proper equipment for handling almost any type of liquid or gas, from nasty chemicals to Jet fuel.

## **DDCouplings<sup>®</sup>** **Dry Disconnect Couplings**



Dry Disconnect Couplings are the given choice for handling any liquid, chemicals, gas etc. where spills can be both costly and hazardous. DDCouplings are available in sizes from 1" to 8". DDCouplings can be found in a lot of various applications such as handling toxic chemicals, fuels etc. to transferring clean water, due to the wide range of materials, connections and sealing types DDCouplings are flexible enough to suit almost any application. Connection according to NATO STANAG 3756

**Applications:** Railcars, ship to shore, tank trucks, chemical plants, food industry, off shore, vessel boats etc.

## **Safety Pressure Caps**

Safety Pressure Caps are designed to be used with the DDCouplings for an even higher safety level, the Safety Pressure Cap is mounted on the DDC tank unit and works this way as a second/third enclosure. The Safety Pressure Cap is equipped with a leakage warning indicator as well as a pressure relief function. Connection according to NATO STANAG 3756



## **DGCouplings<sup>®</sup>** **Dry Gas Couplings**



Dry Gas Couplings are a further development from the DDCouplings specially designed to handle LPG (Liquified Petroleum Gas) even during the toughest conditions. DGCouplings are available in sizes from 1" to 8" and various types of connections to handle almost any type of LPG transferring. According to standard EN 13760:2003(E).

**Applications:** Railcars, tank trucks, "bob trucks", containers etc.

## **DACouplings<sup>®</sup>** **Dry Aviation Couplings**



Dry Aviation Couplings are specially designed for handling aviation fuel, the DACouplings are designed and manufactured according to STANAG 3105 / ISO45 / MS 24484 which are common standards for aviation fuelling logistics.

**Applications:** Dispenser trucks, fuel sampling, military installation. etc.

## **Swivels** **Swivel Joints**



Swivels are used to allow free rotation movement between hoses, nozzles pipes etc. and are available in sizes from 3/4" to 10" and in various types of connections and materials to suit almost any application.

**Applications:** Off shore, tank trucks, industrial applications etc.

## **FFBall Valves**

### **Full Flow Ball Valves**



FFBallvalves are specially designed for handling different types of fuels such as diesel, gasoline, Jet fuel etc in tank trucks. Due to the special design of the FFBallvalves a very good flow is achieved and the turbulence is minimized which results in higher flexibility and easier implementation.

FFBallvalves are available in two types, one-way (one inlet, one outlet) or two-way (one inlet, two outlets) and are available in sizes from 2" to 4".

**Applications:** Aviation, military and tank trucks

## **SBCouplings<sup>®</sup>**

### **Safety Break-away Couplings**



Safety Break-away Couplings are designed to prevent pull-away accidents when loading or unloading tank trucks, railcars, vessel boats etc. Safety Break-away Couplings are available in sizes from 1" to 12".

SBCouplings are available in two types, Marine and Industrial Break-away. Any model you choose you will be guaranteed a high safety level and minimize the risk of unwanted spills.

**Applications:** Railcars, tank trucks, ship to shore etc.

## **DCCouplings**

### **Dry Cryogenic Couplings**



The Dry Cryogenic Coupling consist of a "tank" unit wich is a type of a non-return valve and a "hose" unit with a valve driven by an internal cam curve to open both valves at the same time. Operation is a single action using a straight forward turning motion to connect the couplings and open flow path. Dry Cryogenic Couplings are available in sizes from 1" to 6".

An initial push and turn action on the hose unit provides engagement with the tank unit, thus locking and sealing the two units together. Further rotation opening the internal valves, thereby allowing full flow with a minimum of pressure drop.

**Applications:** Container discharge, Fuel bunkering, Loading/unloading of tank trucks, rail tankers, bunkering and tank vessels, Vapor recovery lines

## **CBCouplings**

### **Cryogenic Break-away Couplings**



Cryogenic Break-away Couplings are a further development of our Safety Break-away Couplings which has successfully been used to prevent pull-away accidents in the petroleum, chemical and LPG industry all over the world. The new range of Cryogenic Break-away Couplings can be installed either at fixed points or in the middle of hose strings. Cryogenic Break-away Couplings are available in sizes from 1" to 6".

**Applications:** Container discharge, Fuel bunkering, Loading/unloading of tank trucks, rail tankers, bunkering and tank vessels, Vapor recovery lines

## Aviation

### Jet Fuel Handling

Loading/unloading of re-fuelers

- 2½"-4" Dry Disconnect Couplings
- Dry Aviation Couplings-ISO45
- Full Flow Ballvalves

Dispensers trucks

- Dry Aviation Couplings -ISO 45
- Full Flow Ball Valves

Hydrant systems

- Sampling, Vent & Drain Unit

### De-icing

Filling of de-icing vehicles

- 2"-3" Dry Disconnect Couplings



## Container

Container transports of liquids: AdBlue, Chemicals etc.

Loading/unloading of liquids containers

- 2"-3" Dry Disconnect Couplings



## Chemical Industry

Handling of: Chemicals, Solvents and Acids

Loading/unloading of tank trucks and railtankersvehicles

- 2"-4" Dry Disconnect Couplings

Blending pits

- 1"-3" Dry Disconnect Couplings



## GAS (LPG)

Handling of LPG

Loading/unloading of tank trucks

- 2"-3" Dry Gas Couplings

Loading/unloading of bobtails

- 2" Dry Gas Couplings

Heavy vehicle filling

- 1" Dry Gas Couplings

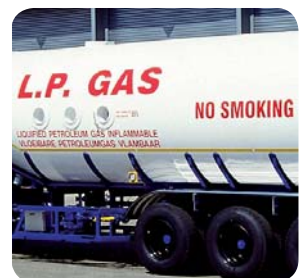

## Rail Tankers

Transport of Chemicals, Fuels, Solvents etc.

Top and bottom loading/unloading

- 2"- 4" Dry Disconnect Couplings
- Safety Pressure Caps





## Military

**Jet fuel and vehicle fuel handling under extreme conditions**

**Loading/unloading of tank trucks and refuelers**

**Portable fuelling stations.**

- 3"-4" Dry Disconnect Couplings
- Dry Aviation Couplings - ISO 45
- Full Flow Ball Valves

- 2"-4" Dry Disconnect Couplings
- Full Flow Ball Valves
- Safety Pressure Caps



## Off Shore

**Transfer of Brine, Diesel, Liquid mud, Methanol etc.**

**Transfer from supply-boat to/from rig.**

**Internal rig handling**

**Jet Fuel handling**

**Helicopter refuelling**

- 2"-8" Dry Disconnect Couplings
- 2"-12" Safety Break-Away Couplings

- 2" Dry Disconnect Couplings

- Dry Aviation Couplings - ISO 45



## Tank Trucks & Petroleum

**Transfer of Petroleum products**

**Loading/unloading of Tank trucks**

**Transfer from trailer to Tank truck**

**Refining of Petroleum products**

**Blending pits**

**Storage handling**

- 3"-4" Dry Disconnect Couplings
- Full Flow Ball Valves

- 3"-4" Dry Disconnect Couplings

- 2"-4" Dry Disconnect Couplings

- 3"-4" Dry Disconnect Couplings

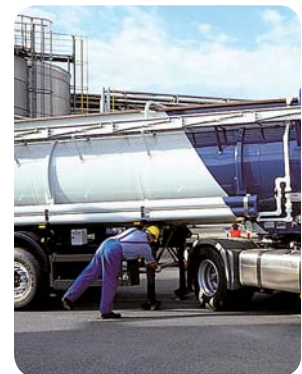

## Cryogenic (LNG)

**Handling of Cryogenic liquefied gases (LNG and Nitrogen)**

**Container discharge**

**Fuel bunkering**

**Loading/unloading of tank trucks, rail tankers**

- 1"-2" Dry Cryogenic Couplings
- Cryogenic Break-away Couplings

- 2½"-6" Dry Cryogenic Couplings
- Cryogenic Break-away Couplings

- 2½"-3" Dry Cryogenic Couplings
- Cryogenic Break-away Couplings



## Product Information



### DDCouplings®

Dry Disconnect Coupling.  
1" to 8", PN 16 - PN 25. Aluminium, Brass-Gunmetal, Stainless Steel and PEEK. Other materials on request. According to NATO standard STANAG 3756.



### DGCouplings®

Dry Gas Coupling.  
1" to 8", PN25. Stainless steel.  
Other materials on request.



### DACouplings,

Dry Aviation Coupling.  
2½", PN 10. Main body in Aluminium.  
**Standards:** ISO 45, MS 24484, NATO STANAG 3105, British Aerospace Spec. 2C14.

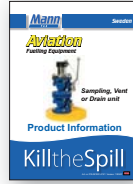

### Sampling, Vent or Drain unit

Stainless Steel SS-EN 10 088-1.4404+AT (AISI 316L). Ball Valve in 1.0619 and 1.4301



### Full Flow - ballvalves

2" to 4", PN 10, Aluminium.  
Ballvalve and 2-way Ballvalve.  
Made for Petroleum Tank Trucks. Variations of flange connections.

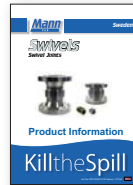

### Swivel joints

¾" to 10", PN 10 - PN 25.  
Aluminium, Brass-Gunmetal, Stainless Steel.  
Other materials on request.  
Connection: BSP, NPT. Flanged connection (DIN, ANSI/ASA e.t.c)



### SBCouplings, bolt series

**Industrial and Marine Safety Break-away, breaking bolts,**  
Aluminium, Brass, Stainless Steel, 1" to 12", female/male threads and with flanges, with breaking bolts.  
**Safety Break-away, cable release**  
Stainless Steel, PN10 / PN 25. 2" to 4", female threads. 6" to 12", flanged connection

## Business Segment Information



Offshore & Marine



Gas (LPG)



Rail tankers



Chemical industry



Tank trucks



Military



Container



Cryogenic Couplings

## Company Information



General Information about Mann Tek, products and Business Segments



Quality, Health, Safety and Environment Policy.  
Quality Approvals, Product Approvals and Declaration of Conformity

## Service



Service instructions and operation manuals

## Your distributor

### Your distributor:

SMAILE-PLUSS SIA Technical centr DANTEC  
Phone: +371 67352561, +371 29214098  
Fax: +371 67352386

Email: office@sptech.lv, info@dantec.lv  
Web site: www.smaile-pluss.lv

Address: Tvaika 52, Riga, LV1005, Latvia

### Contact Mann Tek for your local distributor

**Phone:** +46 501 39 32 00  
**Fax:** +46 501 39 32 09  
**Email:** sales@mann-tek.com  
**Web site:** www.mann-tek.com

**Address:** Mann Teknik AB  
Strandvägen 16  
SE-542 31 Mariestad  
Sweden



Mann-Tek is a certified ISO9001-company.